

SKINTOP® MS-IS-M

SKINTOP® MS-IS-M, brass cable gland for industrial connectors with short connection thread for more space and variable clamping ranges

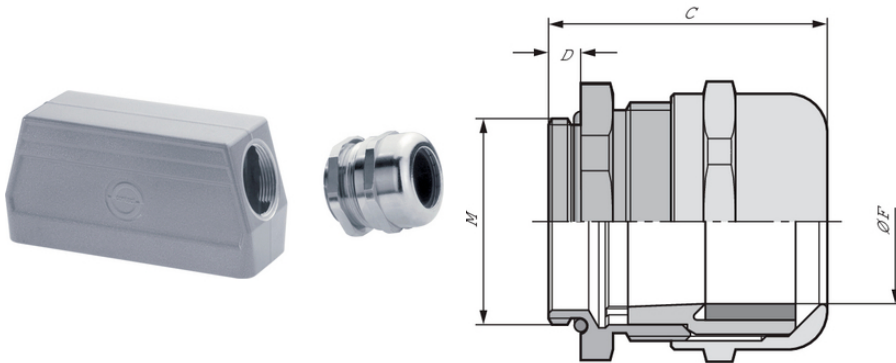

Mechanical and plant engineering



Optimum strain relief



Robust



Connector with standard housing unit



Temperature-resistant

Benefits

Short connection thread for more space inside the industrial connectors
Wide, variable clamping ranges
Optimum strain relief

Application range

Specially designed for use on industrial connectors

Product Make-up

Metric connection thread acc. to DIN EN 60423
Basis for technical information DIN IEC 62444

Included

Rectangular connector is not included, just the cable gland

Last Update (16.12.2022)

©2022 Lapp Group - Technical changes reserved

Product Management www.lappkabel.de

You can find the current technical data in the corresponding data sheet.

PN 0456 / 02_03.16

SKINTOP® MS-IS-M

Technical Data

Classification ETIM 5:	ETIM 5.0 Class-ID: EC000441 ETIM 5.0 Class-Description: Cable screw gland
Classification ETIM 6:	ETIM 6.0 Class-ID: EC000441 ETIM 6.0 Class-Description: Cable screw gland
Caution:	Refer to Appendix T21 for the installation dimensions and torques
Material:	Body: nickel-plated brass Insert: polyamide Sealing: CR O-ring: NBR
Protection rating:	IP 68 - 5 bar
Temperature range:	Dynamic: -25°C up to +100°C Fixed: -40°C up to +100°C

Note

Photographs and graphics are not to scale and do not represent detailed images of the respective products. Prices are net prices without VAT and surcharges. Sale to business customers only.

SKINTOP® MS-IS-M

Article number	Article designation / size	Ø F mm	SW wrench size mm	Overall length C mm	Thread length D mm	Pieces / PU
SKINTOP® MS-IS-M						
53112780	M 25 x 1,5	11 - 18	30	37.0	5	25
53112790	M 32 x 1,5	16 - 25	40	43.0	5	25

Last Update (16.12.2022)

©2022 Lapp Group - Technical changes reserved

Product Management www.lappkabel.de

You can find the current technical data in the corresponding data sheet.

PN 0456 / 02_03.16