

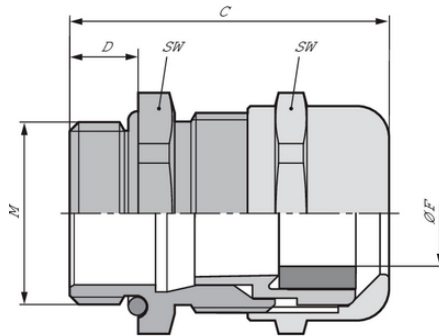







## SKINTOP® MS-M-XL

SKINTOP® MS-M-XL, metric nickel-plated brass cable with wide, variable clamping ranges, especially for thick walls

### Info

With IP69 approval! Proven to withstand the most demanding cleaning procedures for industrial machinery with high-pressure cleaners and hot water!



-  Good chemical resistance
-  Corrosion-resistant
-  Mechanical resistance
-  Optimum strain relief
-  Acid-resistant
-  Temperature-resistant
-  Variety of approval certifications

### Benefits

Especially for thick walls  
 Maximum reliability  
 Optimum strain relief  
 Wide, variable clamping ranges

Last Update (15.05.2025)

©2025 Lapp Group - Technical changes reserved

Product Management [www.lappkabel.de](http://www.lappkabel.de)

You can find the current technical data in the corresponding data sheet.

PN 0456 / 02\_03.16

## SKINTOP® MS-M-XL

### Application range

With long connection thread for applications involving a thicker wall  
In areas where mechanical and chemical stability are critical  
Chemical industry  
Measurement and control technology  
Machine and equipment manufacturing

### Norm references / Approvals

UL File Nr. E79903

### Product Make-up

Metric connection thread acc. to DIN EN 60423  
Basis for technical information DIN IEC 62444

### Technical Data

Classification ETIM 5:	ETIM 5.0 Class-ID: EC000441 ETIM 5.0 Class-Description: Cable screw gland
Classification ETIM 6:	ETIM 6.0 Class-ID: EC000441 ETIM 6.0 Class-Description: Cable screw gland
Caution:	Refer to Appendix T21 for the installation dimensions and torques
Material:	Body: nickel-plated brass Insert: polyamide Sealing: CR O-ring: NBR
Protection rating:	IP 68 - 10 bar IP 69 NEMA Type 1, 4x, 6, 12
Temperature range:	Dynamic: -25 °C up to +100 °C Fixed: -40 °C to +100 °C

### Note

Photographs and graphics are not to scale and do not represent detailed images of the respective products.  
Prices are net prices without VAT and surcharges. Sale to business customers only.



## SKINTOP® MS-M-XL

Article number	Article designation / size	Ø F mm	SW wrench size mm	Overall length C mm	Thread length D mm	Pieces / PU
SKINTOP® MS-M-XL						
53112005	M 12 x 1,5	3.5 - 7.0	16	32.0	12	100
53112015	M 16 x 1,5	4.5 - 10.0	20	38.0	12	50
53112025	M 20 x 1,5	7 - 13.0	24	41.0	12	50
53112035	M 25 x 1,5	9 - 17.0	29	42.5	12	25
53112045	M 32 x 1,5	11 - 21.0	36	51.5	15	25
53112055	M 40 x 1,5	19 - 28.0	45	54.5	15	10
53112065	M 50 x 1,5	27 - 35.0	54	60.5	15	5

Last Update (15.05.2025)

©2025 Lapp Group - Technical changes reserved

Product Management [www.lappkabel.de](http://www.lappkabel.de)

You can find the current technical data in the corresponding data sheet.

PN 0456 / 02\_03\_16