

SKINTOP® MS-SC NPT

SKINTOP® MS-SC NPT, brass cable gland with highly conductive, flexible EMC contact, for cables with and without inner sheath

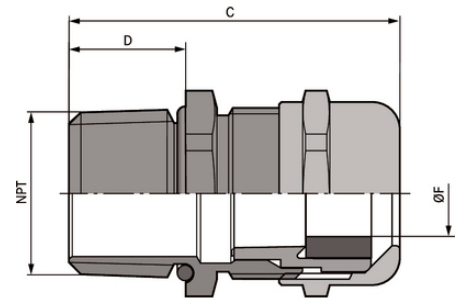

Reliability



Interference signals



Temperature-resistant



Variety of approval certifications

Benefits

- Low-resistance screen contact, optimum EMC protection
- Suitable for cables with and without inner sheath
- Also suitable for continuing the cable screen to another connection
- Highly conductive, flexible EMC contact for clamping various screen diameters
- Few operation steps, easy to assemble

Application range

- For EMC-compliant earthing of the copper braiding
- Automation technology
- Telecommunication
- Measurement and control technology
- Industrial machinery and plant engineering

Norm references / Approvals

UL File Nr. E79903

Product Make-up

NPT connection thread acc. to ASME B1.20.1 - 2013

Last Update (10.12.2022)

©2022 Lapp Group - Technical changes reserved

Product Management www.lappkabel.de

You can find the current technical data in the corresponding data sheet.

PN 0456 / 02_03.16

SKINTOP® MS-SC NPT

Technical Data

Classification ETIM 5:	ETIM 5.0 Class-ID: EC000441 ETIM 5.0 Class-Description: Cable screw gland
Classification ETIM 6:	ETIM 6.0 Class-ID: EC000441 ETIM 6.0 Class-Description: Cable screw gland
Material:	Body: nickel-plated brass Insert: polyamide Sealing: CR O-ring: NBR
Protection rating:	IP 68 - 10 bar NEMA Type 1, 4x, 6, 12
Temperature range:	Dynamic: -25°C up to +100°C Fixed: -40°C up to +100°C

Note

Photographs and graphics are not to scale and do not represent detailed images of the respective products. Prices are net prices without VAT and surcharges. Sale to business customers only.

SKINTOP® MS-SC NPT

Article number	Article designation / size	Ø F mm	SW wrench size mm	Overall length C mm	Thread length D mm	Pieces / PU
SKINTOP® MS-SC NPT						
53112910	NPT 3/8"	4.5 - 10	20	39.7	15	100
53112920	NPT 1/2"	7 - 13	24	42.5	15	50
53112930	NPT 3/4"	9 - 17	29	44.5	15	25
53112940	NPT 1"	11 - 21	36	49.0	15	25
53112950	NPT 1 1/4"	19 - 28	45	57.5	17	10
53112960	NPT 1 1/2"	27 - 35	54	61.5	17	5

Last Update (10.12.2022)

©2022 Lapp Group - Technical changes reserved

Product Management www.lappkabel.deYou can find the current technical data in the corresponding data sheet.
PN 0456 / 02_03_16