

## EPIC® H-A 32 AD-BO

Rugged housings for 2 inserts

The metal housing with a seal and pivots for a double lever is suitable for control systems and for space-saving installations.

### Info

Compact, robust metal housings for double size H-A 32

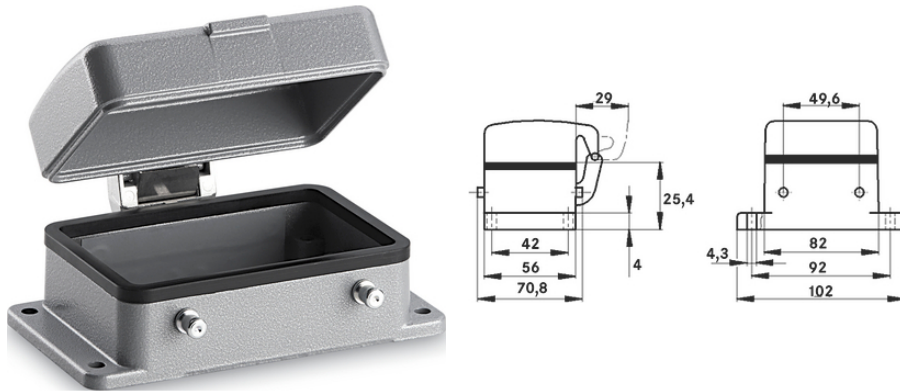

Mechanical and plant engineering



Mechanical resistance



Robust



Waterproof

### Benefits

For two inserts of the small H-A, H-D and STA series. Space-saving

### Application range

Machine and equipment manufacturing  
Control engineering

### Product features

H-A case: Wall base  
Bolts for double lever  
Metal cover  
Included: flat gasket

### Technical Data

Last Update (28.03.2026)

©2026 Lapp Group - Technical changes reserved

Product Management [www.lappkabel.de](http://www.lappkabel.de)

You can find the current technical data in the corresponding data sheet.

PN 0456 / 02\_03.16

**EPIC® H-A 32 AD-BO**

Classification ETIM 5:	ETIM 5.0 Class-ID: EC000437 ETIM 5.0 Class-Description: Housing for industrial connectors
Classification ETIM 6:	ETIM 6.0 Class-ID: EC000437 ETIM 6.0 Class-Description: Housing for industrial connectors
Material:	Housing: aluminium alloy, grey Lever: zinc-plated steel Sealing: NBR
Protection rating:	IP 65 (latched) IP 40 (cover closed)
Temperature range:	-40 °C to +100 °C, short-term up to +125 °C

**Note**

Photographs and graphics are not to scale and do not represent detailed images of the respective products.  
Prices are net prices without VAT and surcharges. Sale to business customers only.



## EPIC® H-A 32 AD-BO

Article number	Article description	M	Packaging unit
H-A housing: panel-mount base (cover, bolts for double lever)			
70503000	H-A 32 AD-BO	AG	5

Last Update (28.03.2026)

©2026 Lapp Group - Technical changes reserved

Product Management [www.lappkabel.de](http://www.lappkabel.de)

You can find the current technical data in the corresponding data sheet.

PN 0456 / 02\_03.16