

EPIC® H-A 32 TSB

Rugged housings for 2 inserts

The compact metal housing can not only be used for machine and device manufacturing. It is suitable for rectangular connectors and can have two narrow inserts installed.

Info

Compact, robust metal housings for double size H-A 32

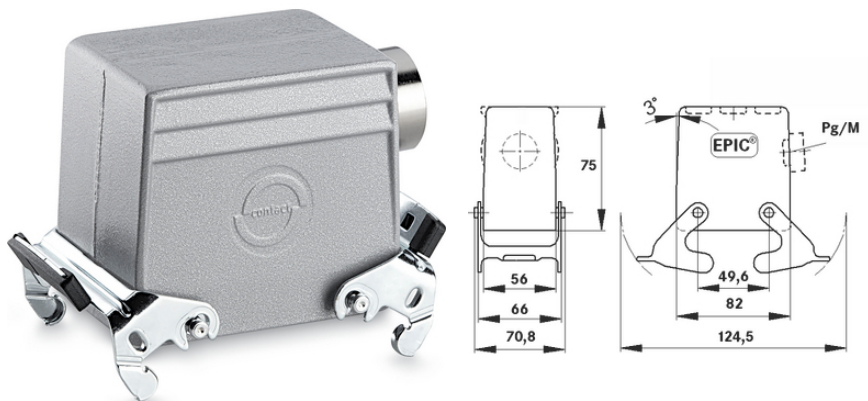

Mechanical and plant engineering



Mechanical resistance



Robust



Waterproof

Benefits

For two inserts of the small H-A, H-D and STA series. Space-saving

Application range

Machine and equipment manufacturing

Control engineering

Product features

Hood

Dual levers

Side cable entry

Versions with / without neck

Last Update (23.04.2024)

©2024 Lapp Group - Technical changes reserved

Product Management www.lappkabel.de

You can find the current technical data in the corresponding data sheet.

PN 0456 / 02_03.16

EPIC® H-A 32 TSB

Technical Data

Classification ETIM 5:	ETIM 5.0 Class-ID: EC000437 ETIM 5.0 Class-Description: Housing for industrial connectors
Classification ETIM 6:	ETIM 6.0 Class-ID: EC000437 ETIM 6.0 Class-Description: Housing for industrial connectors
Material:	Housing: aluminium alloy, grey Lever: zinc-plated steel Sealing: NBR
Protection rating:	IP 65 (latched)
Temperature range:	-40°C to +100°C, short-term up to +125°C

Note

Photographs and graphics are not to scale and do not represent detailed images of the respective products.
Prices are net prices without VAT and surcharges. Sale to business customers only.

EPIC® H-A 32 TSB

Article number	Article description	M	PG	Neck	Pieces / PU
H-A housing: hood (side cable entry, double lever)					
10578000	H-A 32 TSB 21	-	21	yes	5
10579000	H-A 32 TSB 29	-	29	yes	5
19578000	H-A 32 TSB M25	25	-	-	5
19579000	H-A 32 TSB M32	32	-	-	5

Last Update (23.04.2024)

©2024 Lapp Group - Technical changes reserved

Product Management www.lappkabel.de

You can find the current technical data in the corresponding data sheet.

PN 0456 / 02_03_16