

EPIC® H-B 16 T

Housing design H-B. The industry standard.

The same, yet better: you'll be impressed with this rectangular connector hood, the design and haptics of which have been completely revamped. While the technical properties and advantages have remained identical, the modern design not only impresses visually, but gives you a much better grip when connecting and disconnecting.

Info

Non-slip ridges for comfortable disconnecting

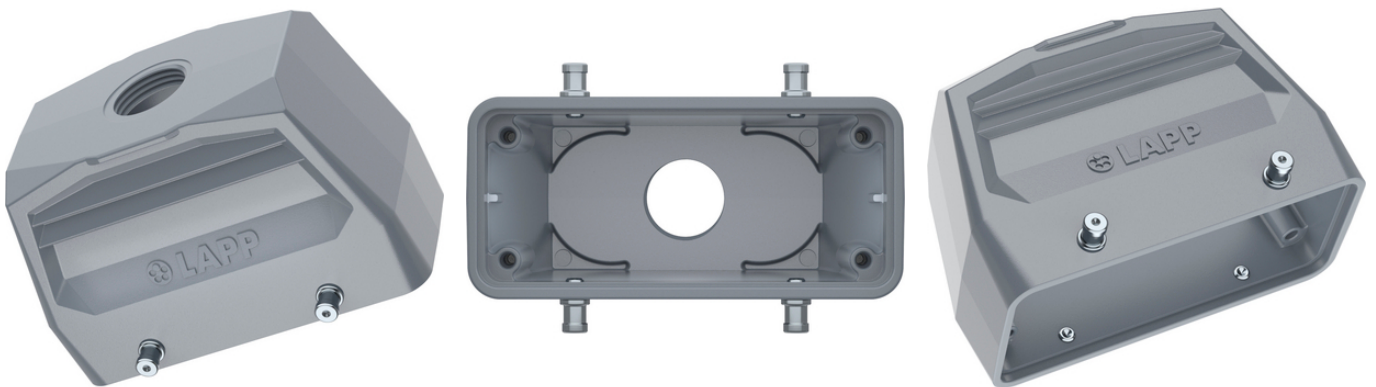

Supplementary automation components from Lapp



Mechanical and plant engineering



Mechanical resistance



Robust



Waterproof

Benefits

The hood housing is mateable with many commercially available housings (panel-mount base, surface-mount base or coupler hood housings).

The user-friendly design with a good grip makes the plug connection easy to connect and release.

Locking takes place using a stainless-steel double lever on the counter-housing.

Corresponds to protection class IP 65 when locked.

UL certification according to technical data enables use of the product in the North American region.

Application range

To protect the connector insert from environmental influences.

Last Update (30.08.2024)

©2024 Lapp Group - Technical changes reserved

Product Management www.lappkabel.de

You can find the current technical data in the corresponding data sheet.

PN 0456 / 02_03.16

EPIC® H-B 16 T

For use with many EPIC® rectangular connector inserts or module inserts.
For power supply connection of devices and machines in various applications.
With modular connector assembly, also suitable for signal and data transmission.
For use with a cable gland or a collar.
Withstands high environmental and mechanical stresses.

Product features

Hood, low version
Bolts for double lever
Straight cable entry

Technical Data

Classification ETIM 5:	ETIM 5.0 Class-ID: EC000437 ETIM 5.0 Class-Description: Housing for industrial connectors
Classification ETIM 6:	ETIM 6.0 Class-ID: EC000437 ETIM 6.0 Class-Description: Housing for industrial connectors
Material:	Housing: powder-coated aluminium alloy, grey Bolts: steel, coated
Protection rating:	IP 65 (latched)
Temperature range:	-40°C to +100°C, short-term up to +125°C

Note

Photographs and graphics are not to scale and do not represent detailed images of the respective products.
Prices are net prices without VAT and surcharges. Sale to business customers only.



EPIC® H-B 16 T

Article number	M	Packaging unit
19080001	20	10

Last Update (30.08.2024)

©2024 Lapp Group - Technical changes reserved

Product Management www.lappkabel.de

You can find the current technical data in the corresponding data sheet.

PN 0456 / 02_03.16